

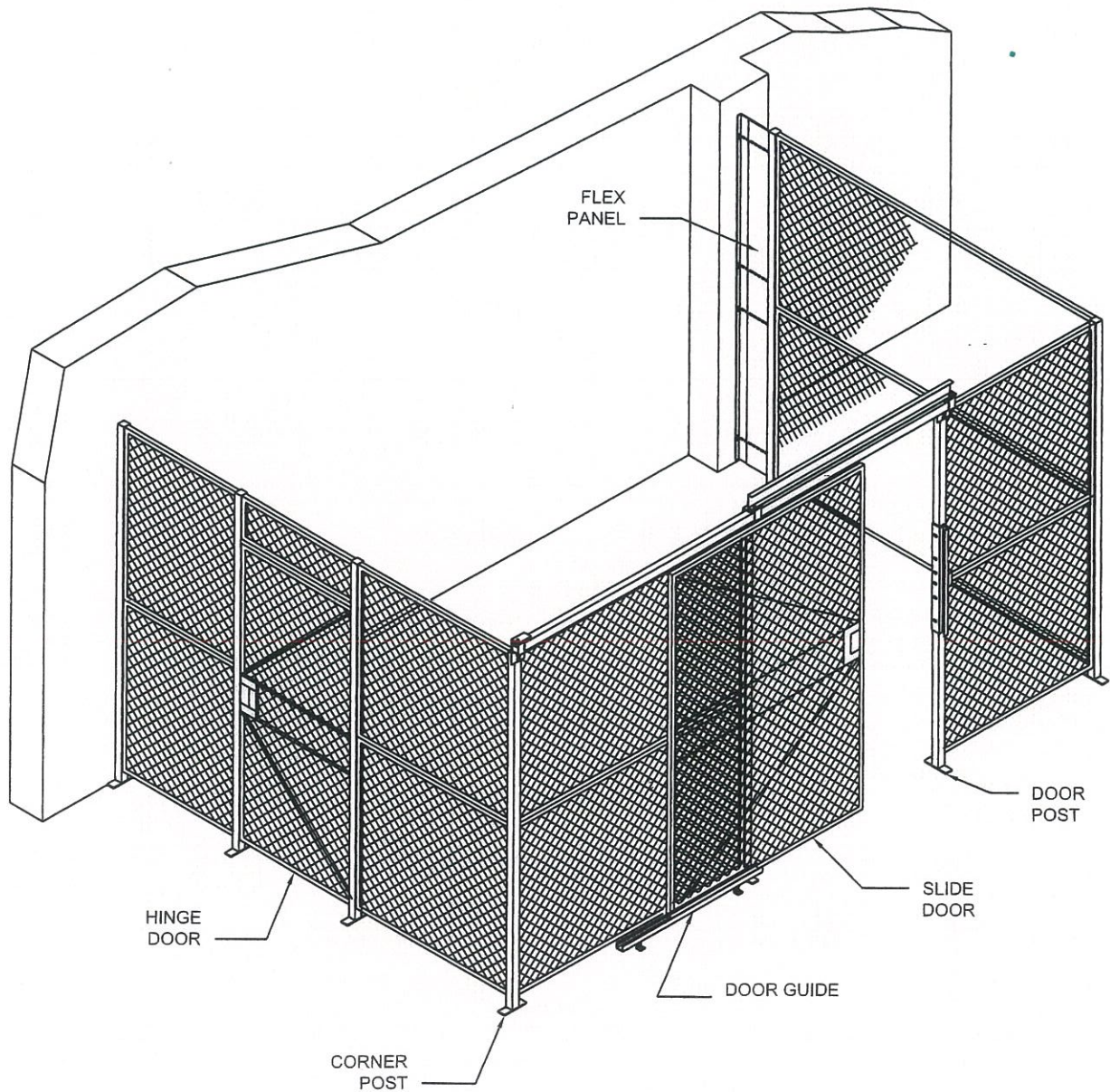

NILES FENCE & SECURITY PRODUCTS

SECUREX – SX3000 STANDARD SIZE SECURITY CAGES AND PARTITIONS

INSTALLATION DETAILS



HINTS FOR PROPER INSTALLATION

DO THIS FIRST: Inventory the material against the accompanying packing list and inspect the material for damages or shortages. If there are damages or shortages found please call the number below immediately.

The basic concept of the SG2000 style wire partition system is to provide utmost simplicity and ease of installation.

<u>Tools Required:</u>		<u>Optional:</u>
SAE wrench set	adjustable wrench	crowbar
screwdriver set	hammer drill & bits	tin snips
SAE torque wrench	standard drill & bits	chalk line
hacksaw	ladder	ext. cord
rubber mallet		

Do – Use chalk lines to help line up panels and posts.

Do – Install the bottom panels around the cage first, then the upper panels and then all doors. Tighten all hardware after all panels are up.

Do – Put a 3 ¼" spacer under the bottom panel to establish the sweep space while hanging the panels. (Spacer is not provided)

Do – Attach hinges to door panels first and then hang the doors on the posts.

Do – Be sure on sliding doors to insert the 5/16" x 1" carriage bolt through the track clamp, the 4.2C bracket, the V7 adaptor and the channel header before securing the nut.

Do – Check all hardware connections from time to time and tighten or adjust as needed.

DON'T – Locate a swing in hinge door at a corner.

DON'T – Anchor posts for a hinge door until correct door setup is made.

DON'T – Locate flex panels next to a door panel

DON'T – Use flex panels in ceilings.

DON'T – Locate sliding door panels at corners unless door can be mounted outside and slide away from corner.





DON'T – Locate padlock style sliding doors on the inside of fence walls.





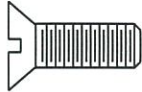
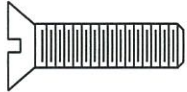
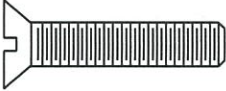
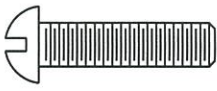
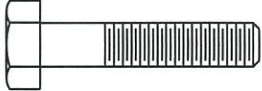
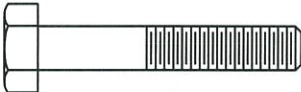

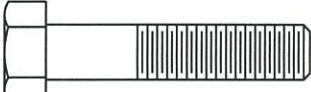
DON'T – Put service windows in panels adjacent to sliding door in the direction in which the door slides.

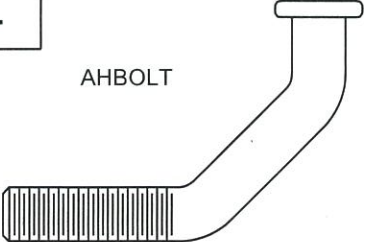
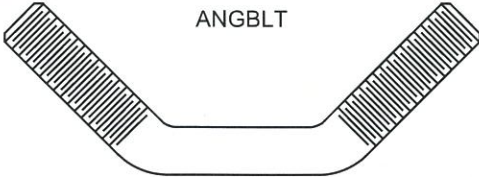
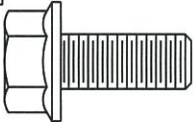
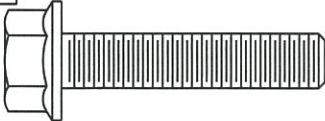
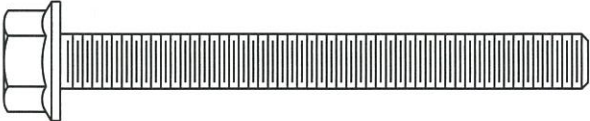

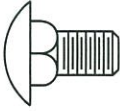
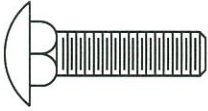
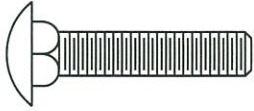
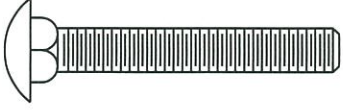
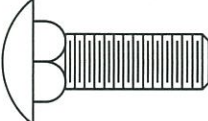
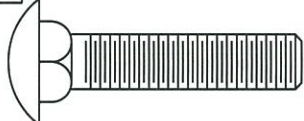
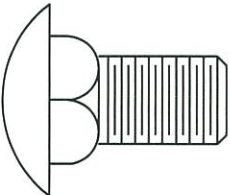

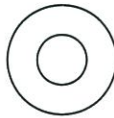
DON'T – Use full height opening sliding doors with partitions that have a ceiling unless door is mounted to the outside of the enclosure.

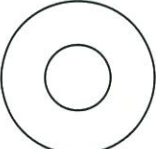
NOTICE – All studs, anchors and associated nuts and bolts shown herein are for reference only and are not included in the hardware kits.

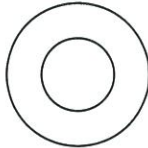
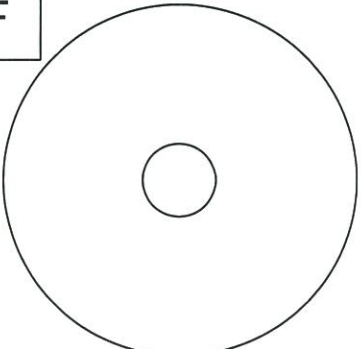
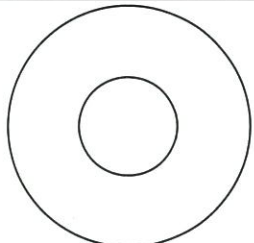
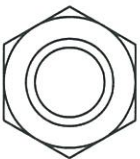
INSTALLATION HINTS_____	2
TABLE OF CONTENTS_____	3
HARDWARE DRAWINGS PG 1_____	4
HARDWARE DRAWINGS PG 2_____	5
HARDWARE DRAWINGS PG 3_____	6
STANDARD CONNECTIONS_____	7
7' HIGH SINGLE HINGE DOOR ASSEMBLY_____	8
DUTCH DOOR ASSEMBLY_____	9
DOUBLE HINGE DOOR ASSEMBLY_____	10
FULL-HEIGHT DOUBLE HINGE DOOR ASSEMBLY_____	11
TYPICAL INSTALLATION 3'-5' FULL-HEIGHT SLIDE DOOR_____	12
3'-5' FULL-HEIGHT SLIDE DOOR ASSEMBLY_____	13
TYPICAL INSTALLATION 3'-5' TRANSOM STYLE SLIDE DOOR_____	14
3'-5' TRANSOM STYLE SLIDE DOOR ASSEMBLY_____	15
TYPICAL INSTALLATION 6'-10' FULL-HEIGHT SLIDE DOOR_____	16
6'-10' FULL-HEIGHT SLIDE DOOR ASSEMBLY_____	17
TYPICAL INSTALLATION 6'-10' TRANSOM STYLE SLIDE DOOR_____	18
6'-10' TRANSOM STYLE SLIDE DOOR ASSEMBLY_____	19
TYPICAL INSTALLATION DOUBLE SLIDE DOOR_____	20
DOUBLE SLIDE DOOR ASSEMBLY_____	21
FLEX PANELS_____	22
SERVICE WINDOWS_____	23
TYPICAL CEILING INSTALLATION PG 1_____	24
TYPICAL CEILING INSTALLATION PG 2_____	25
JSC INSTALLATION_____	26
SPECIAL APPLICATION FOR TRACK SUPPORT_____	27

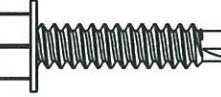
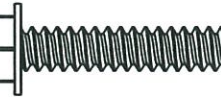
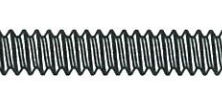
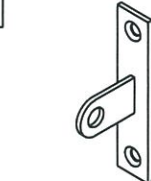
A	 <p>Flat Head Screw 1/4 X 1/2</p>	B	 <p>Flat Head Screw 1/4 X 3/4</p>	C	 <p>Flat Head Screw 1/4 X 1</p>
D	 <p>Flat Head Screw 1/4 X 1 1/4</p>	E	 <p>Round Head Bolt 1/4 X 1</p>	F	 <p>Hex Head Bolt 1/4 X 1 1/4</p>
G	 <p>Hex Head Bolt 1/4 X 1 1/2</p>	H	 <p>Round Head Bolt 5/16 X 1</p>	I	 <p>Hex Head Bolt 5/16 X 1</p>
J	 <p>Hex Head Bolt 5/16 X 1 1/2</p>	K		 <p>Hex Head Bolt 5/16 X 3</p>	
L	 <p>AHBOLT</p>	M	 <p>ANGLBT</p>	N	 <p>Flange Hex Bolt 5/16 X 3/4</p>
O	 <p>Flange Hex Bolt 5/16 X 1 1/2</p>	P		 <p>Flange Hex Bolt 5/16 X 3</p>	

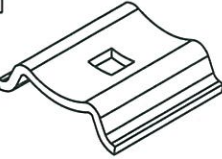
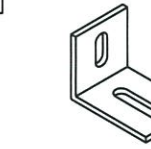
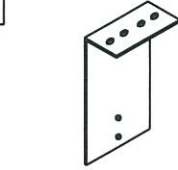
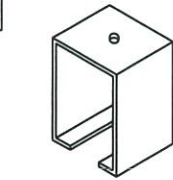
Q	 <p>Carriage Bolt 1/4 X 1/2</p>	R	 <p>Carriage Bolt 1/4 X 1</p>	S	 <p>Carriage Bolt 1/4 X 1 1/2</p>
T	 <p>Carriage Bolt 1/4 X 1 3/4</p>	U	 <p>Carriage Bolt 5/16 X 1</p>	V	 <p>Carriage Bolt 5/16 X 1 1/2</p>
W	 <p>Carriage Bolt 1/2 X 1</p>	X	 <p>Lock Washer 1/4</p>	Y	 <p>Flat Washer 1/4</p>
Z	 <p>Hex Nut 1/4</p>	AA	 <p>Lock Washer 5/16</p>	BB	 <p>Flat Washer 5/16</p>
CC	 <p>Hex Nut 5/16</p>	DD	 <p>Flange Hex Nut 5/16</p>	EE	 <p>Flat Washer 3/8</p>
FF	 <p>Fender Washer 3/8</p>	GG	 <p>Flat Washer 1/2</p>	HH	 <p>Hex Nut 1/2</p>

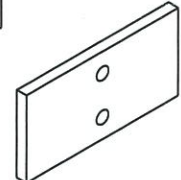
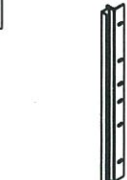
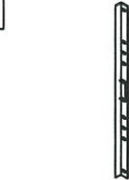
II		JJ		KK	
	 <p>Self Tap Screw 1/4 X 1</p>		 <p>Self Tap Screw 1/4 X 1 1/4</p>		 <p>Self Tap Screw 1/4 X 1 1/2</p>
LL	 <p>Self Tap Screw 1/4 X 2</p>	MM	<p>(Not to scale)</p>  <p>Plrcvr</p>	NN	<p>(Not to scale)</p>  <p>Atflug</p>
OO	<p>(Not to scale)</p>  <p>Wclip</p>	PP	<p>(Not to scale)</p>  <p>Angle Bracket</p>	QQ	<p>(Not to scale)</p>  <p>V7 Adaptor</p>
RR	<p>(Not to scale)</p>  <p>4.2C</p>	SS	<p>(Not to scale)</p>  <p>2 Wheel Trolley</p>	TT	<p>(Not to scale)</p>  <p>Abracket</p>
UU	<p>(Not to scale)</p>  <p>APV7H (X2)</p>	VV	<p>(Not to scale)</p>  <p>AFSDPLAR</p>	WW	<p>(Not to scale)</p>  <p>HDLR</p>

FLEX PANEL

If your partition has a width not covered by our stock panels, use Flex Panels instead of having custom panels made. Flex panels can be used for widths from 2" to 12"

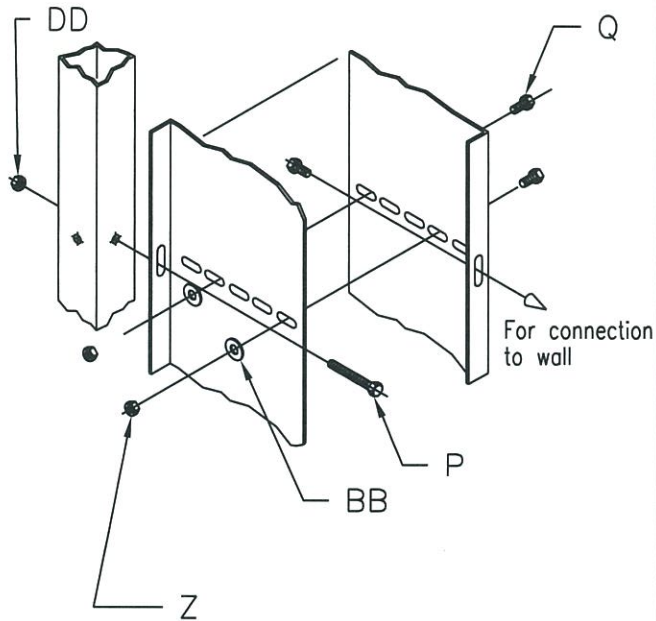

LINE POST CONNECTIONS

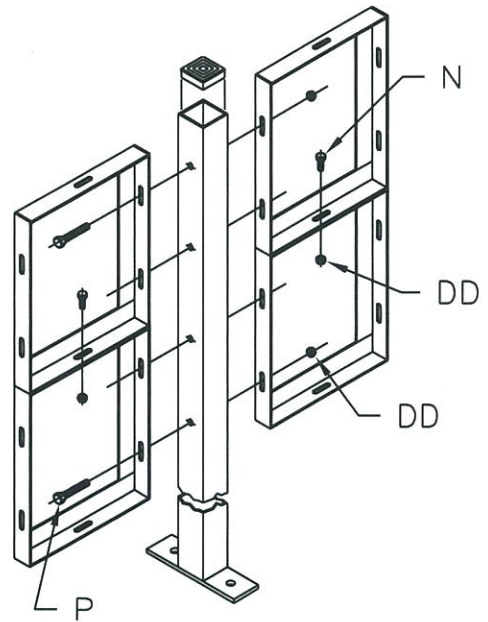

CORNER POST CONNECTION

For connection of Panels at a corner
Use Hardware Kit - ACPK

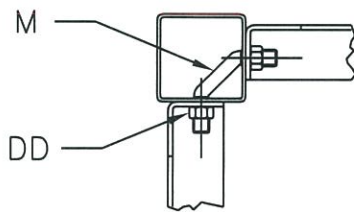

THREE WAY CONNECTION

For connections at an intersection
Use Hardware Kit - ATPK

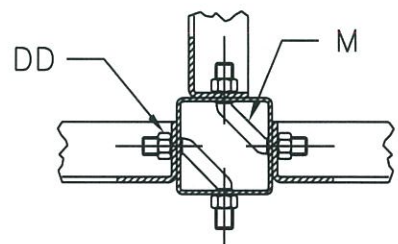

TYPICAL WALL CONNECTIONS

For connecting panels to various wall types
(Hardware not provided)

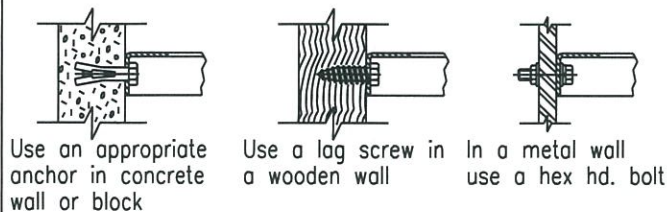

TYPICAL FLOOR ANCHORING CONNECTION

For connecting Standard Posts to a concrete floor
(Hardware not provided)

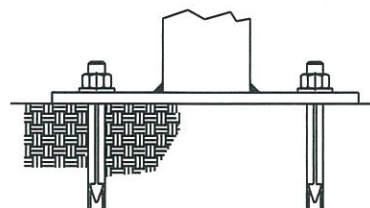

7' HIGH SWING DOOR ASSEMBLY (AHD38 SHOWN)

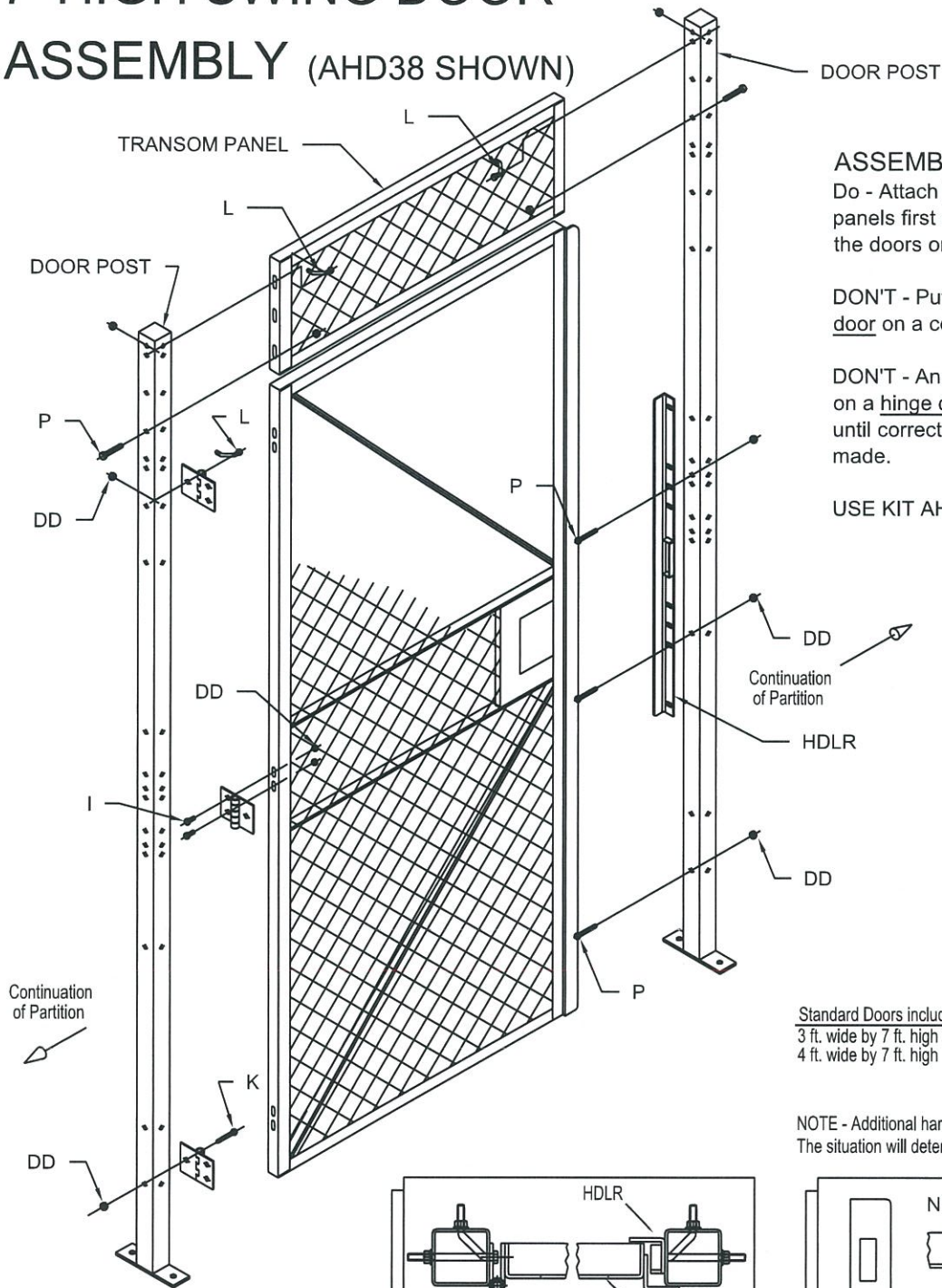

ASSEMBLY NOTES:

Do - Attach hinges to door panels first and then hang the doors on the posts.

DON'T - Put a swing in hinge door on a corner.

DON'T - Anchor both posts on a hinge door to the floor until correct door setup is made.

USE KIT AHDK

Standard Doors include
 3 ft. wide by 7 ft. high (Shown)
 4 ft. wide by 7 ft. high

NOTE - Additional hardware is provided. The situation will determine what you use.

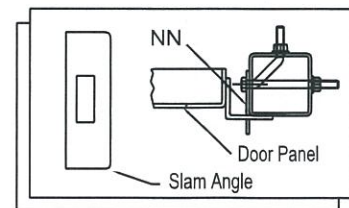
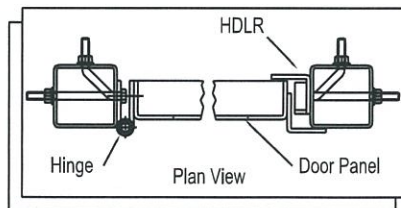

(Option Padlock Arrangement)
 APLAR

Dutch Door 8 ft. Cage

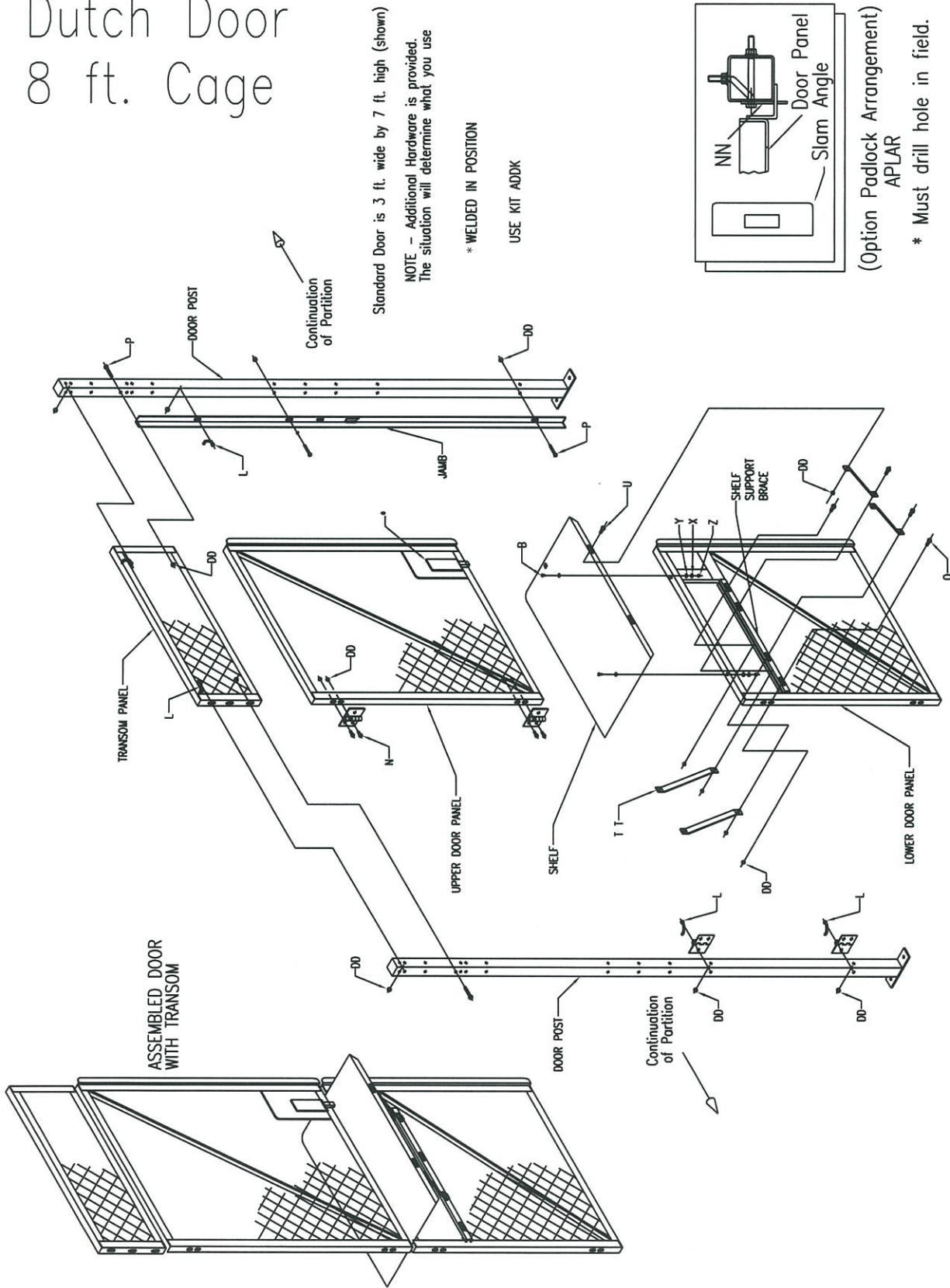

(Option Padlock Arrangement)
APLAR
* Must drill hole in field.

BI-PARTING SWING DOOR (FULL HEIGHT)

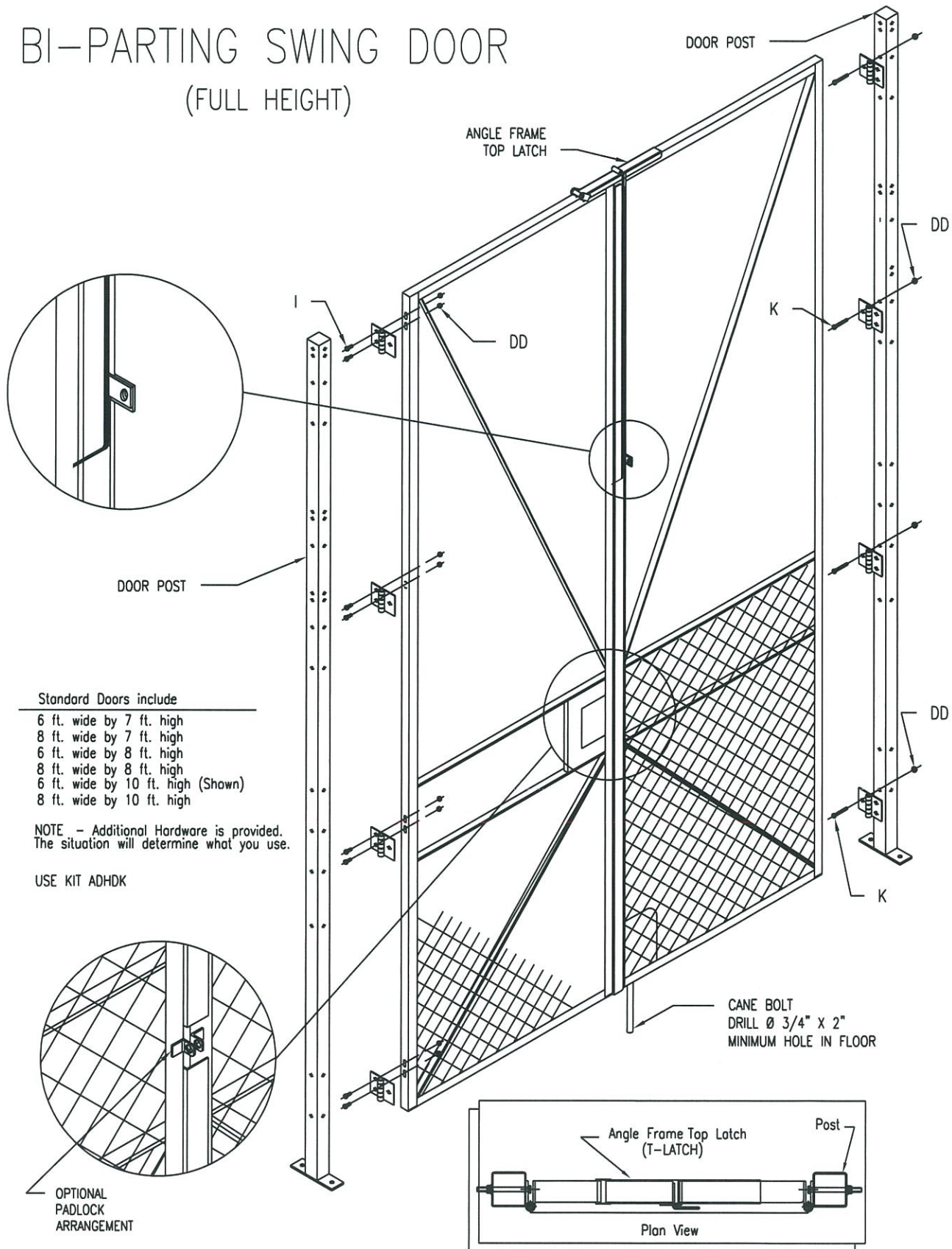

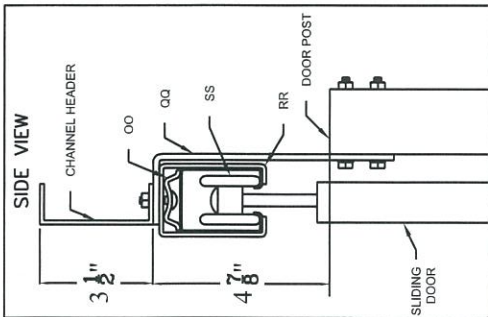

5/16" X 1" Carriage bolt will pass through: wclip, 4.2C, V7Adaptor and channel header before adding and securing nut. (30ft. lb torque)

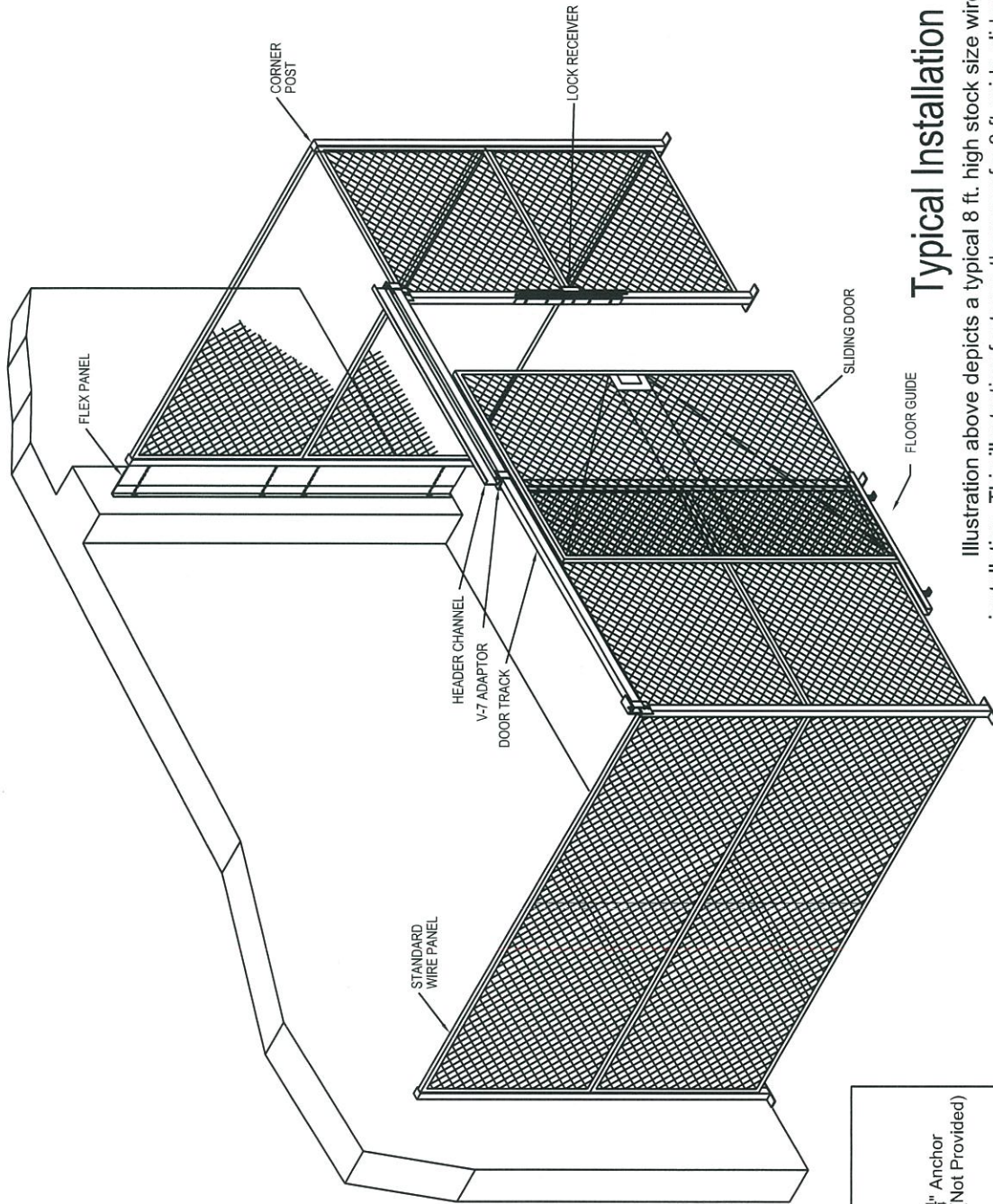

Typical Installation

Illustration above depicts a typical 8 ft. high stock size wire partition installation. This illustration features the use of a 3 ft. wide slide door panel that is 8 ft. high. Also shown is the flex panel.

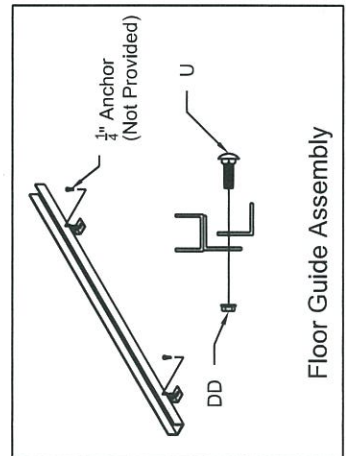

3'-5' FULL-HEIGHT STYLE SLIDE DOOR ASSEMBLY

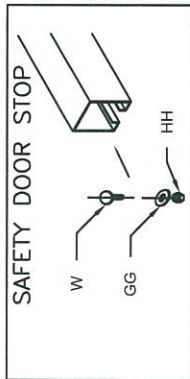
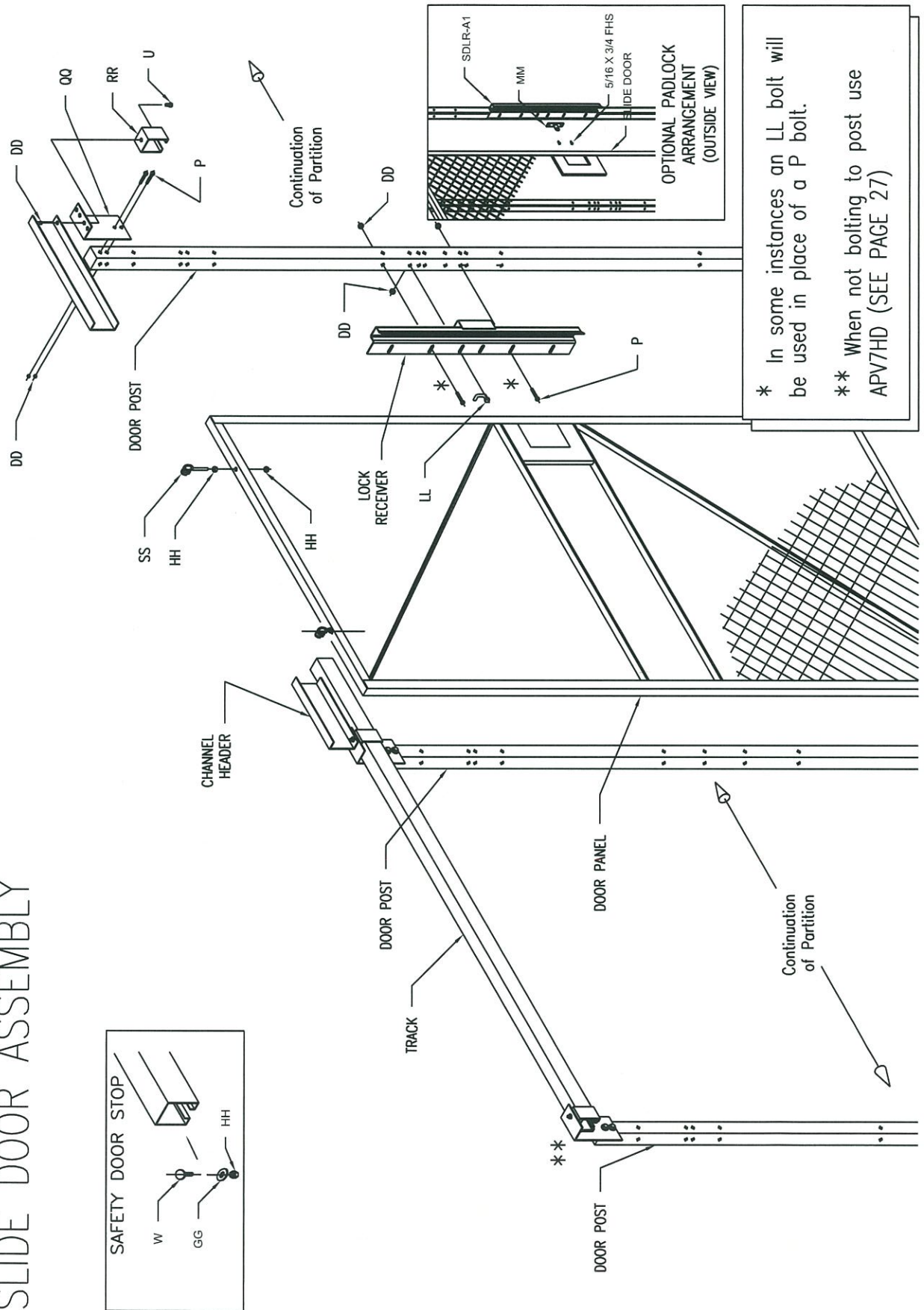

* In some instances an LL bolt will be used in place of a P bolt.

** When not bolting to post use APV7HD (SEE PAGE 27)

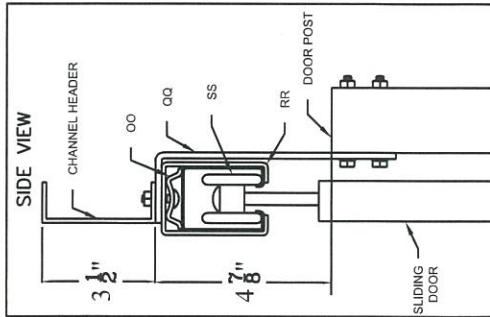

$\frac{5}{16}$ " X 1" Carriage bolt will pass through: wclip, 4.2C, V7Adaptor and channel header before adding and securing nut. (30ft. lb torque)

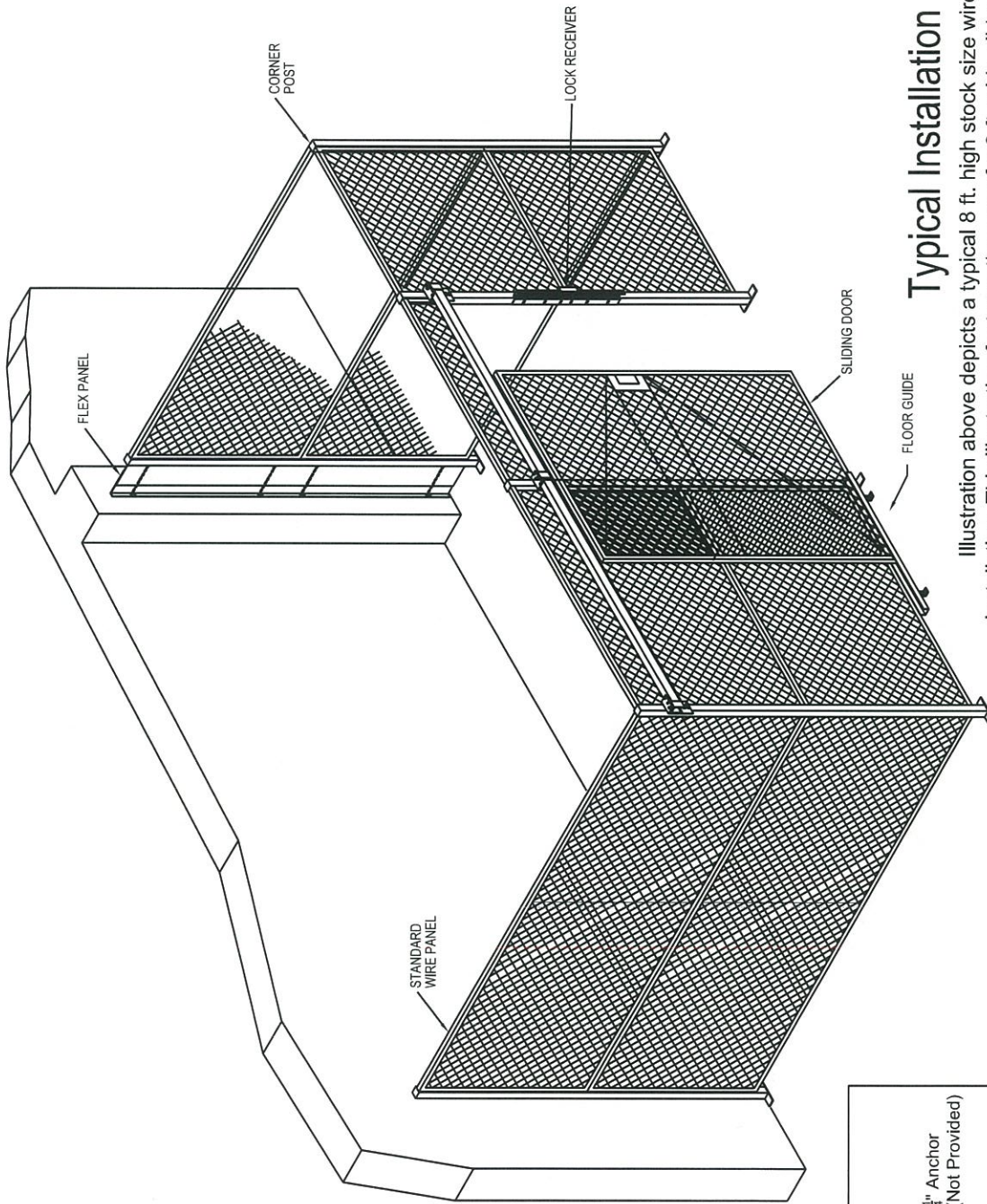

Typical Installation

Illustration above depicts a typical 8 ft. high stock size wire partition installation. This illustration features the use of a 3 ft. wide slide door panel that is 7 ft. high with a transom above. Also shown is the flex panel.

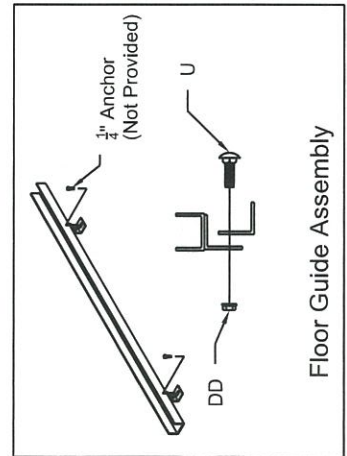

Floor Guide Assembly

3'-5' TRANSOM STYLE SLIDE DOOR ASSEMBLY

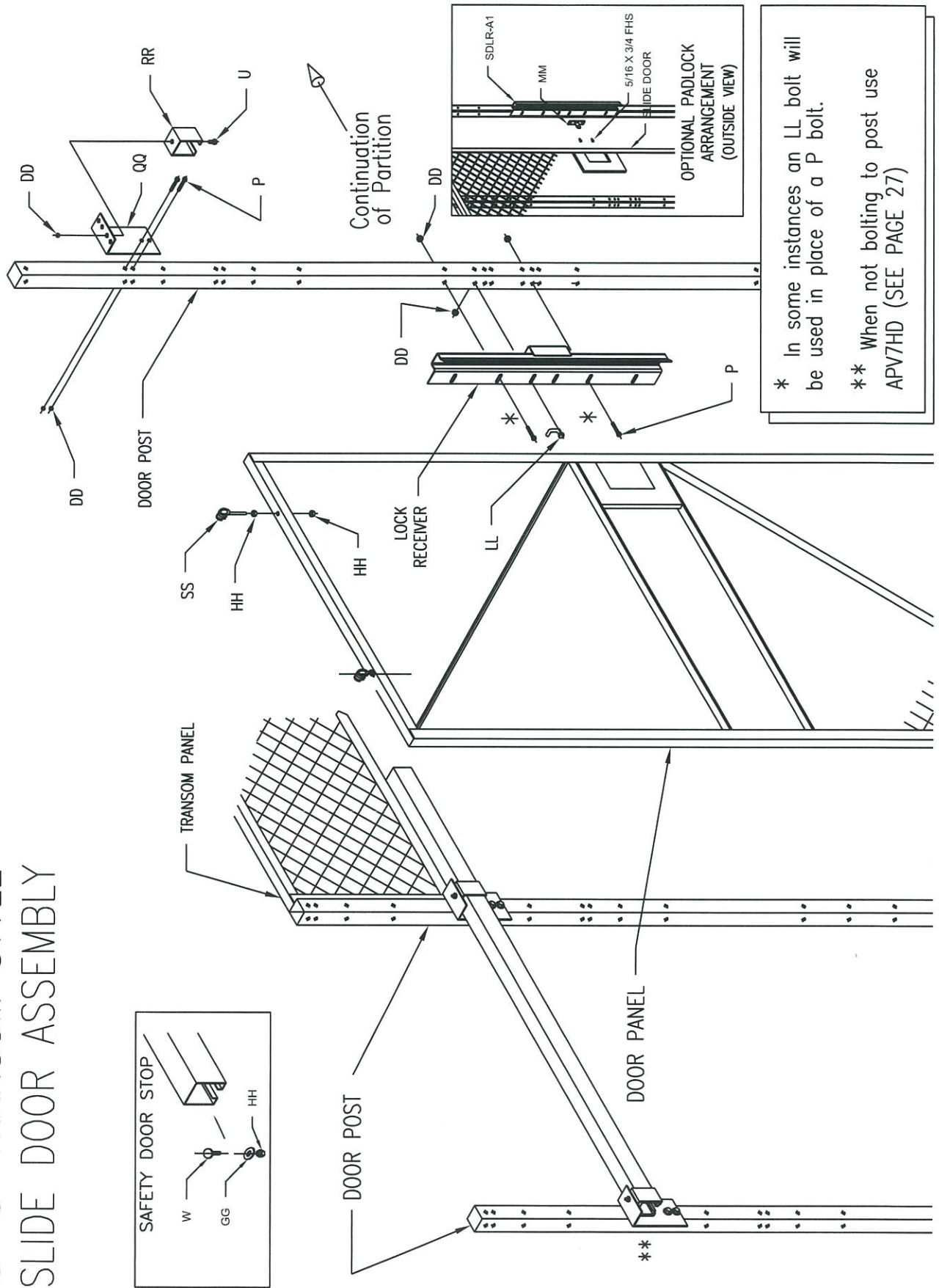

* In some instances an LL bolt will be used in place of a P bolt.
 ** When not bolting to post use APV7HD (SEE PAGE 27)

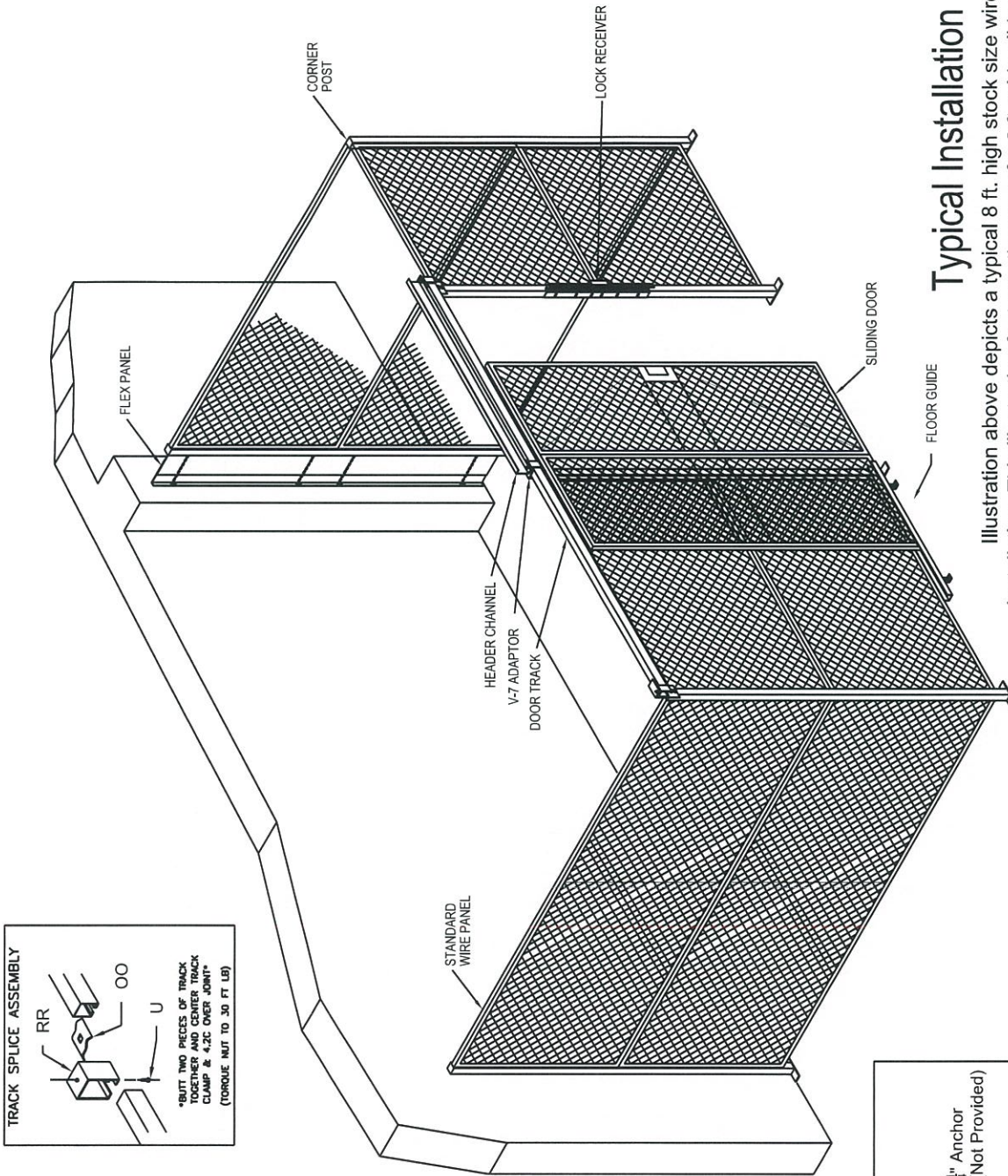

Typical Installation

Illustration above depicts a typical 8 ft. high stock size wire partition installation. This illustration features the use of a 6 ft. wide slide door panel that is 8 ft. high. Also shown is the flex panel.

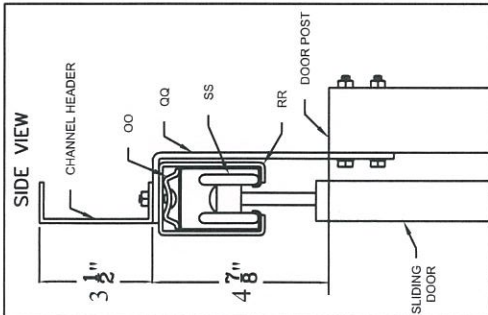
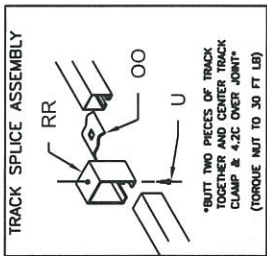

5/16" X 1" Carriage bolt will pass through: wclip, 4.2C, V7Adaptor and channel header before adding and securing nut. (30ft. lb torque)

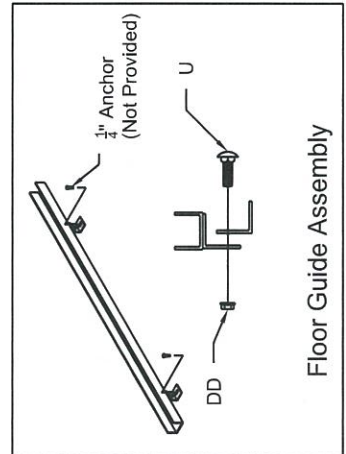

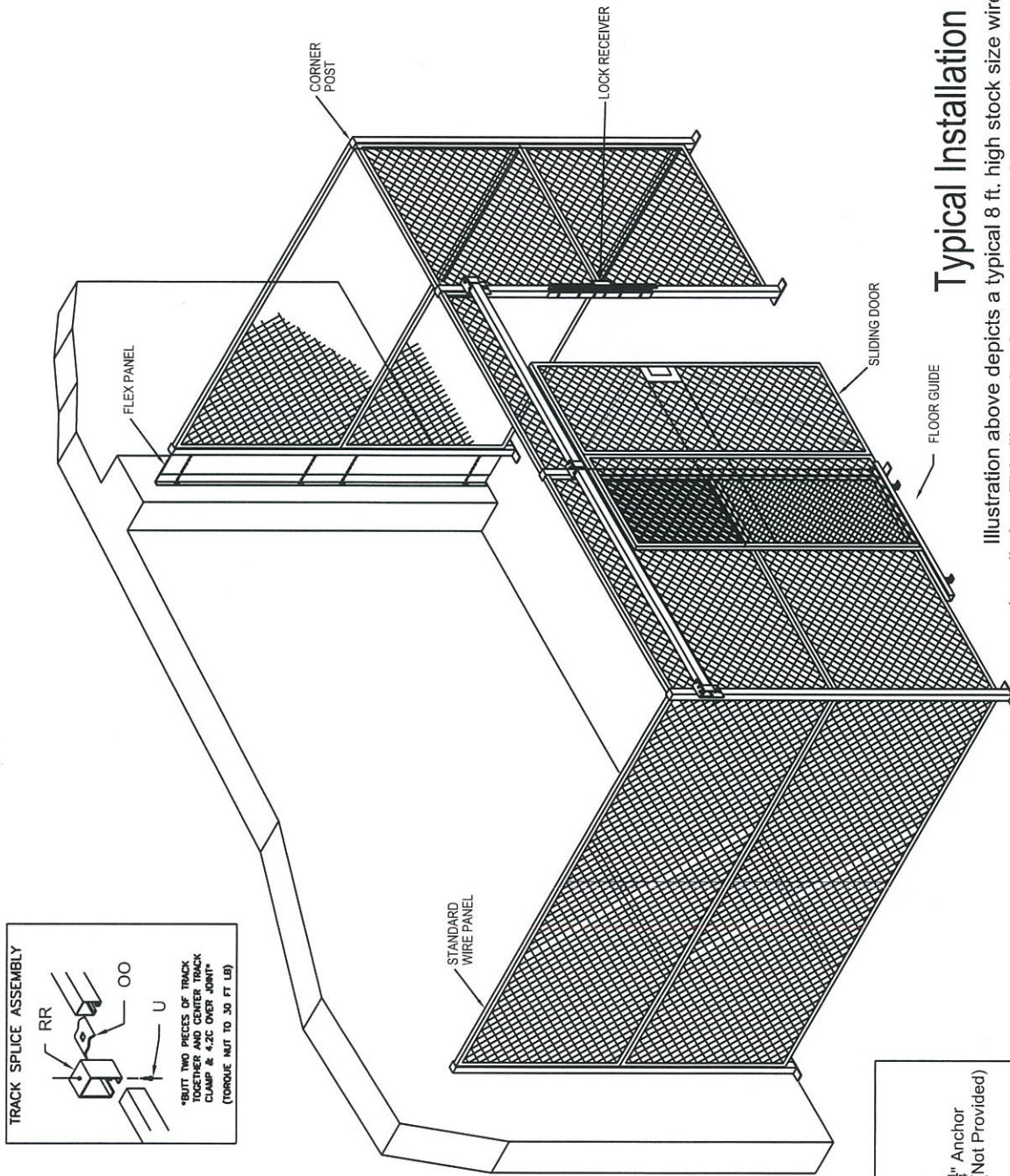

Typical Installation

Illustration above depicts a typical 8 ft. high stock size wire partition installation. This illustration features the use of a 6 ft. wide slide door panel that is 7 ft. high with a transom above. Also shown is the flex panel.

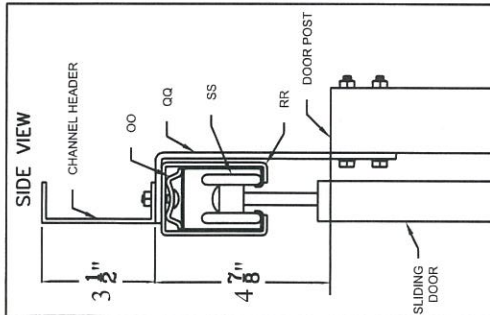
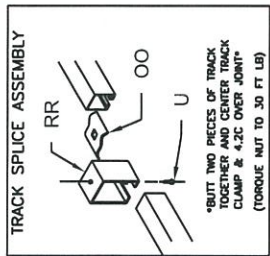

5/16" X 1" Carriage bolt will pass through: wclip, 4.2C, V7Adaptor and channel header before adding and securing nut. (30ft. lb torque)

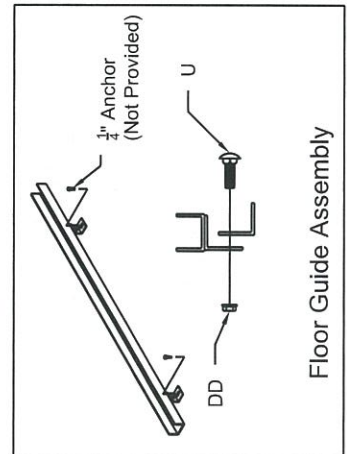

6'-10' TRANSOM STYLE SLIDE DOOR ASSEMBLY

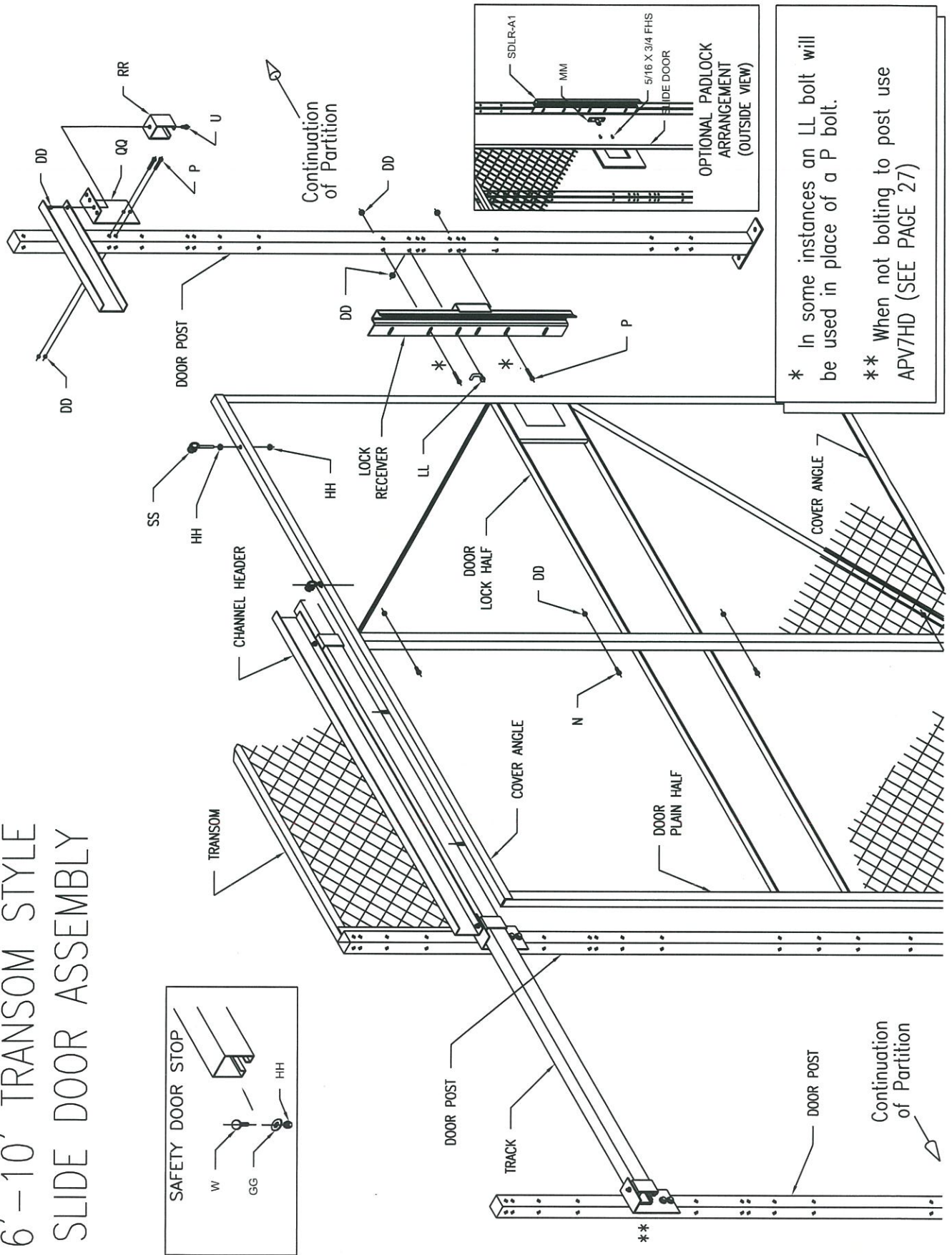

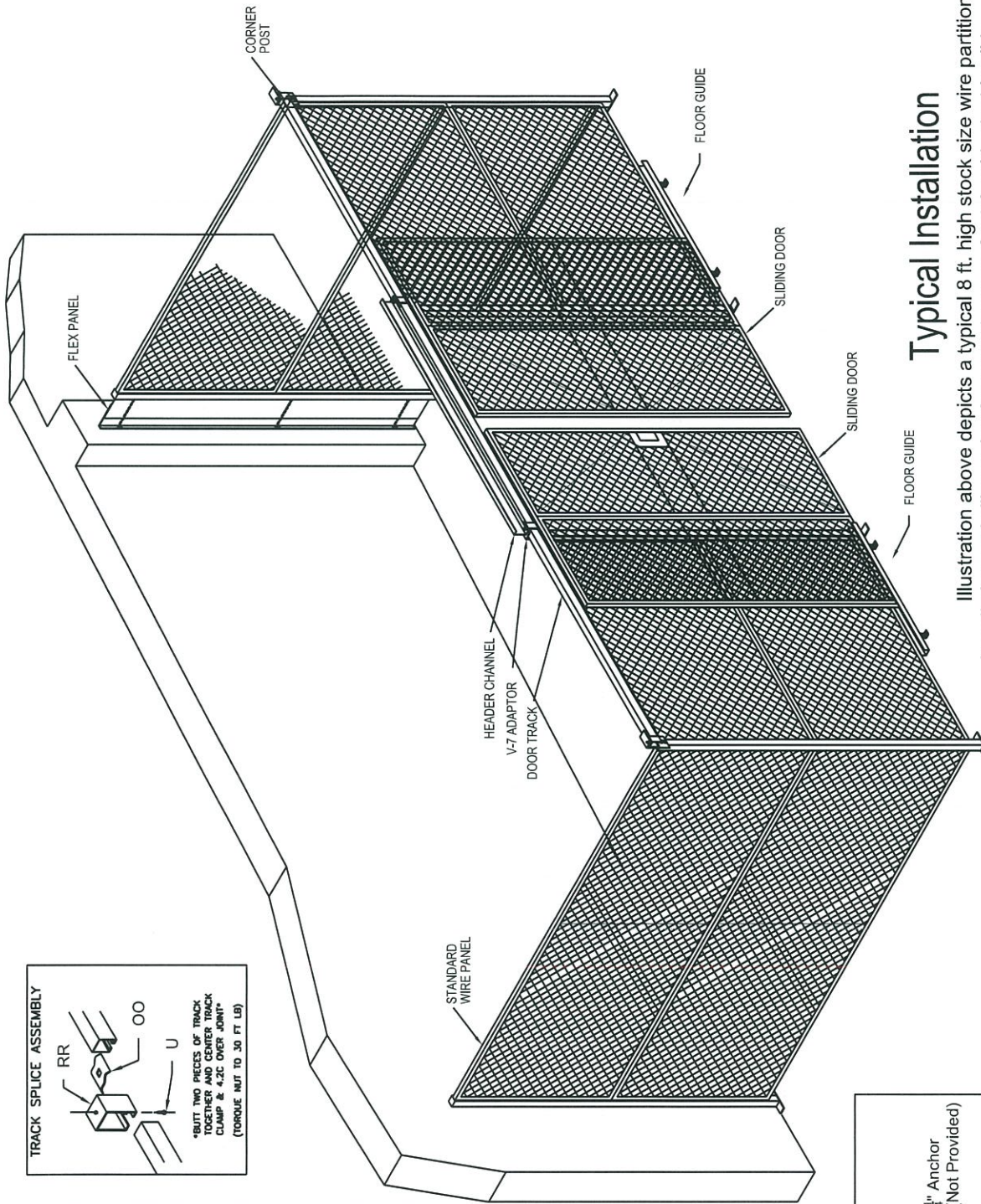

Typical Installation

Illustration above depicts a typical 8 ft. high stock size wire partition installation. This illustration features the use of a 6 ft. wide double slide door panel that is 8 ft. high. Also shown is the flex panel.

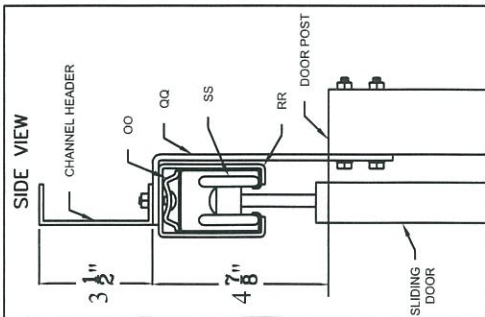
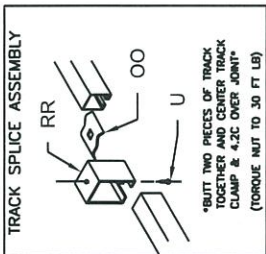

5/16" X 1" Carriage bolt will pass through: wclip, 4.2C, V7Adaptor and channel header before adding and securing nut. (30ft. lb torque)

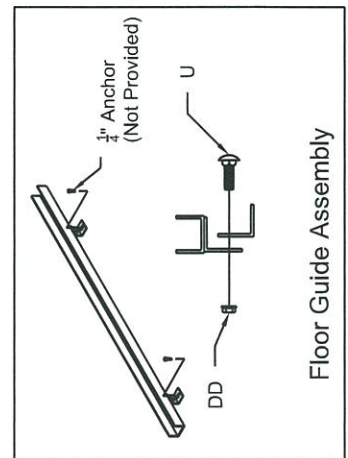

DOUBLE SLIDE DOOR ASSEMBLY

For transom style door, track will mount to posts at door height. (See page 19 for reference)

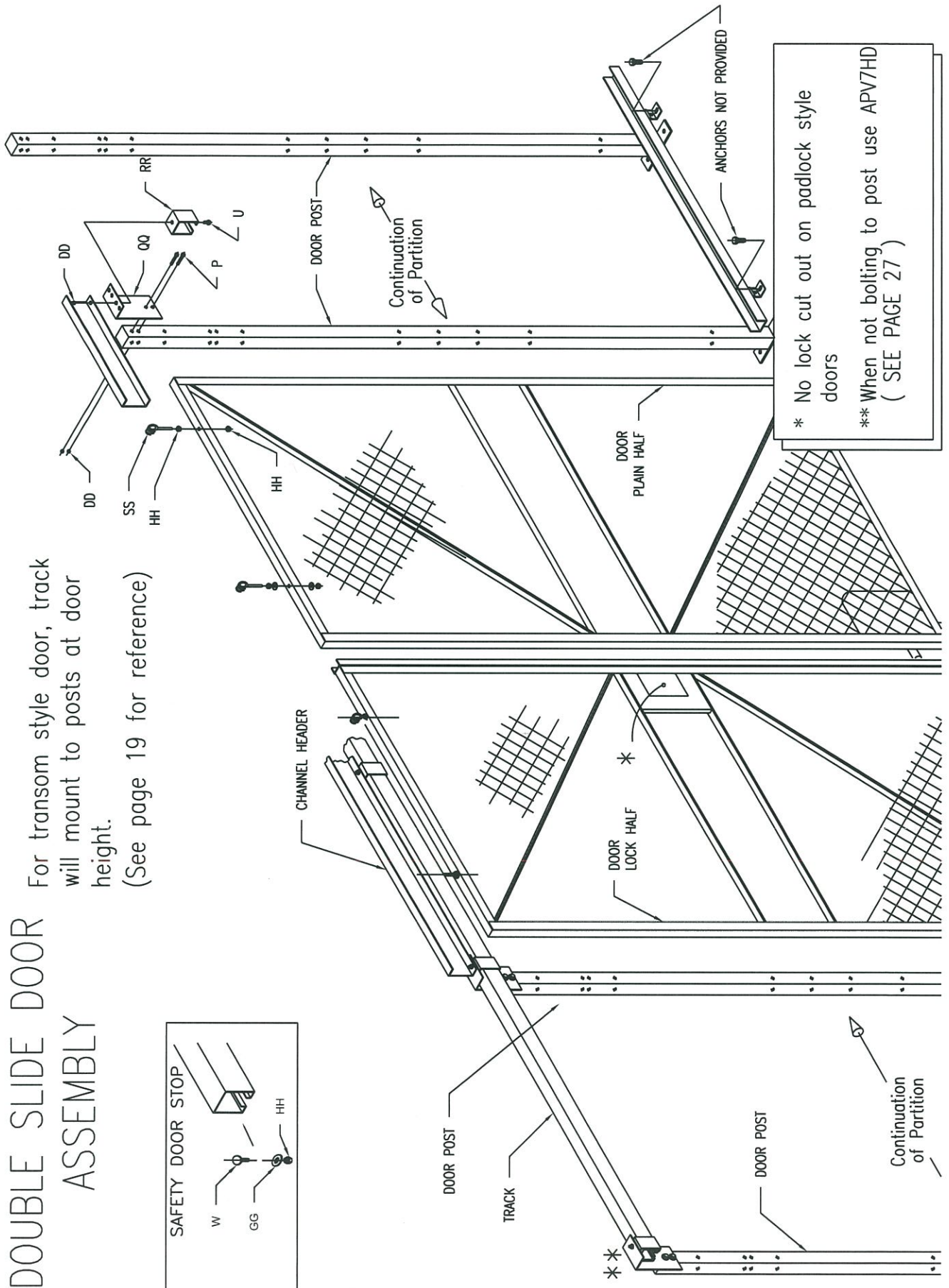
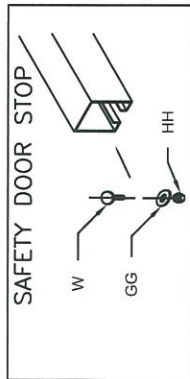

* No lock cut out on padlock style doors
 ** When not bolting to post use APV7HD (SEE PAGE 27)

Flex Panel

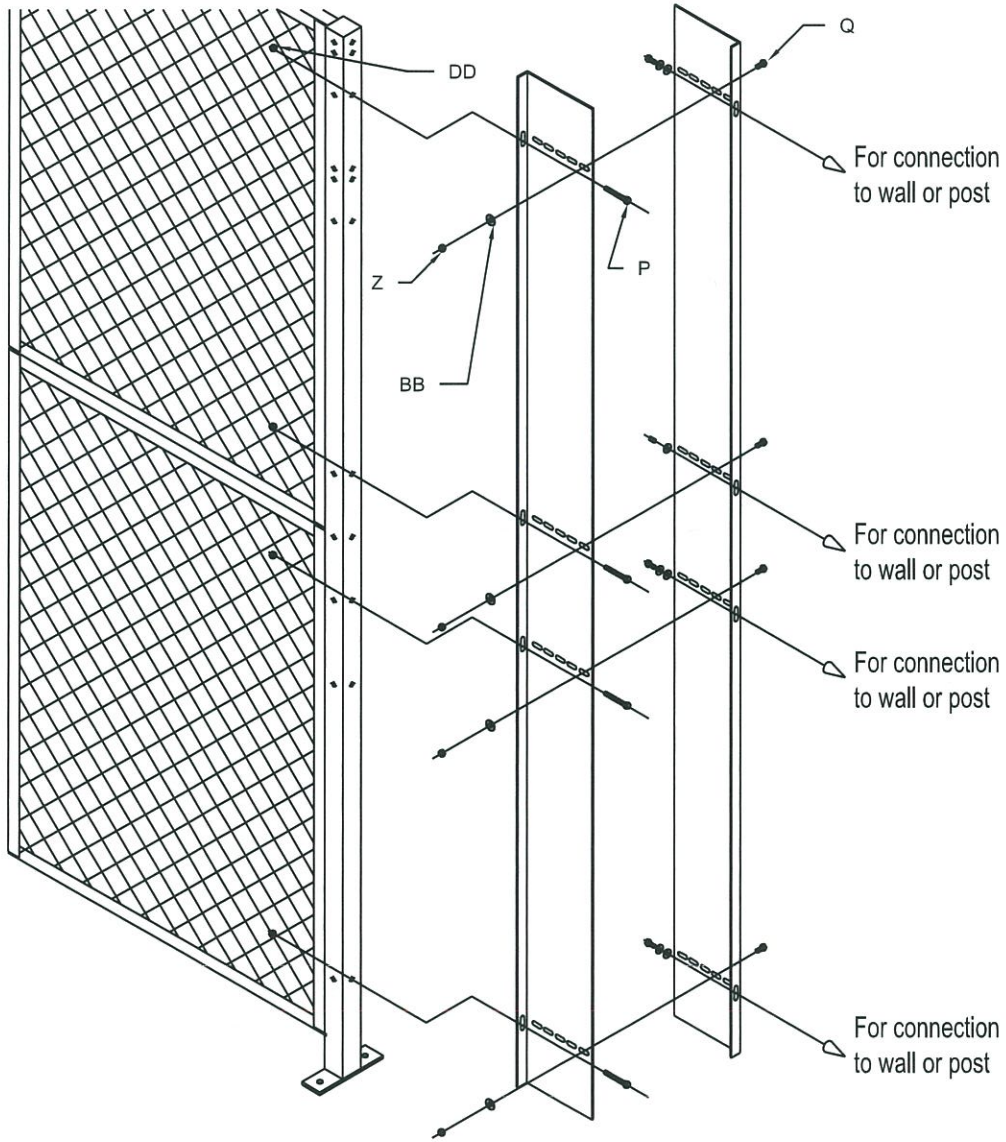

Available in 8 ft. & 10 ft.
heights standard.
For openings from 2" to 12"

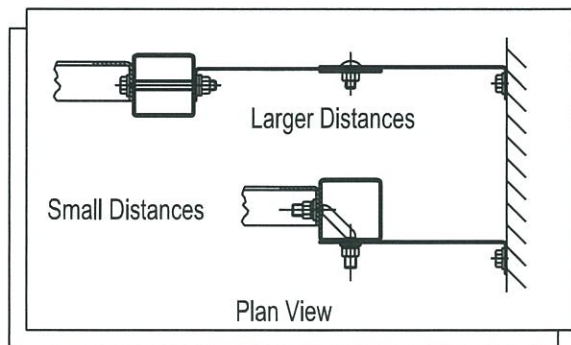

Service Windows

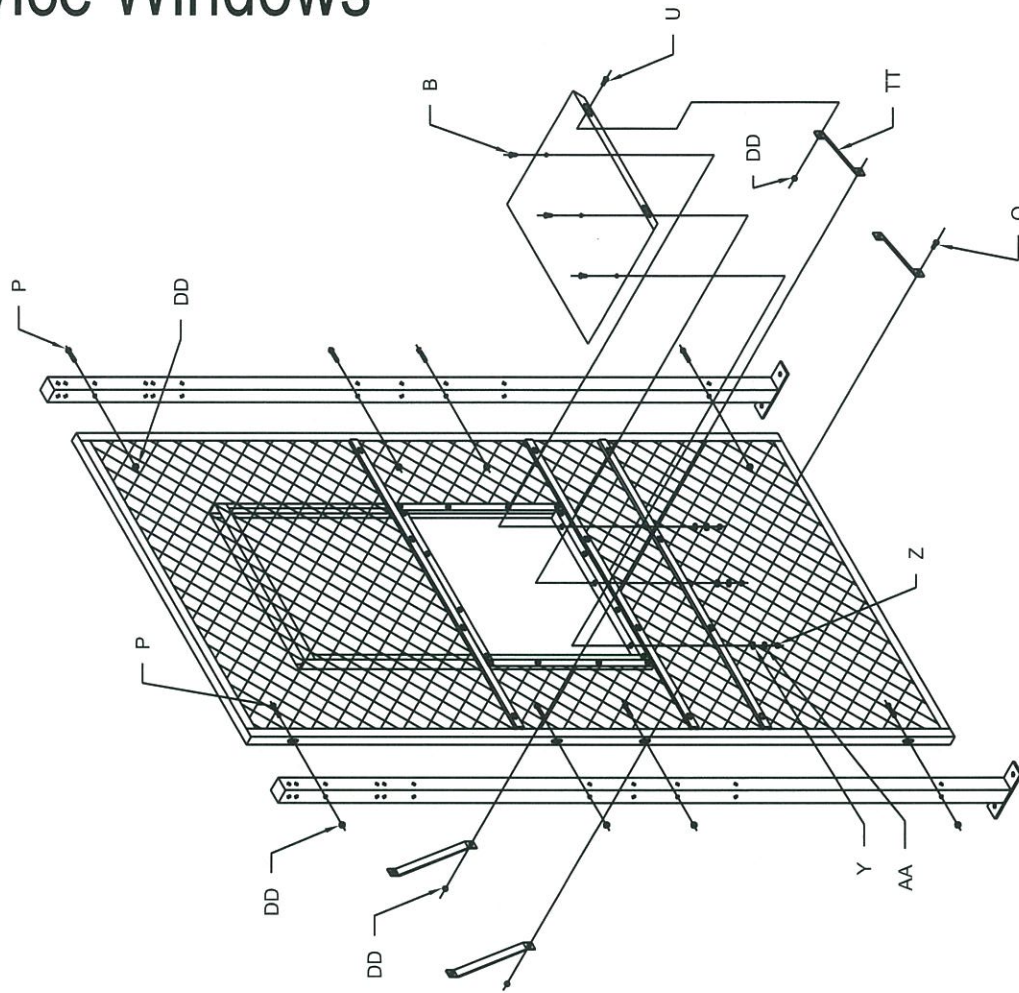

Sliding Service Window
(Inside View)

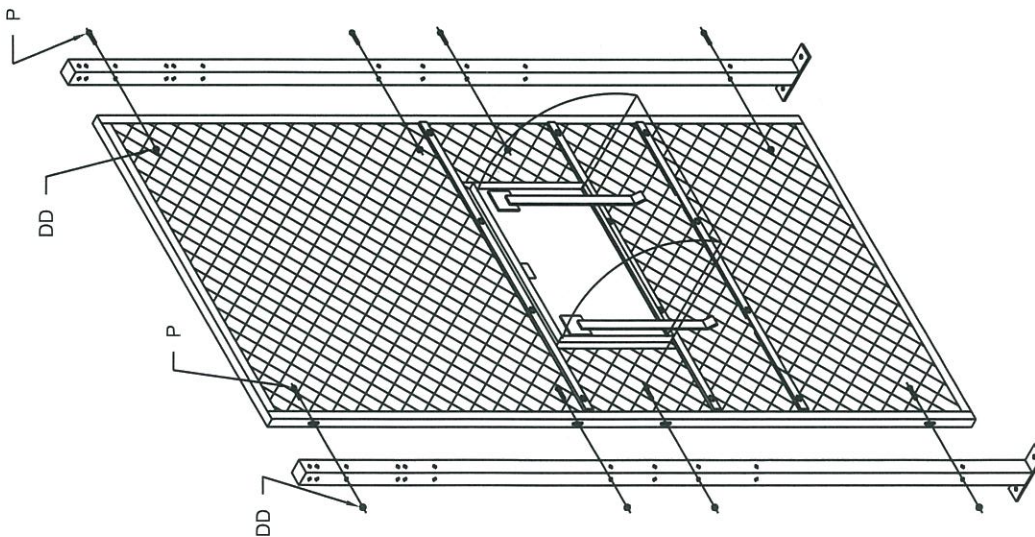

Combination Service Window
(Inside View)

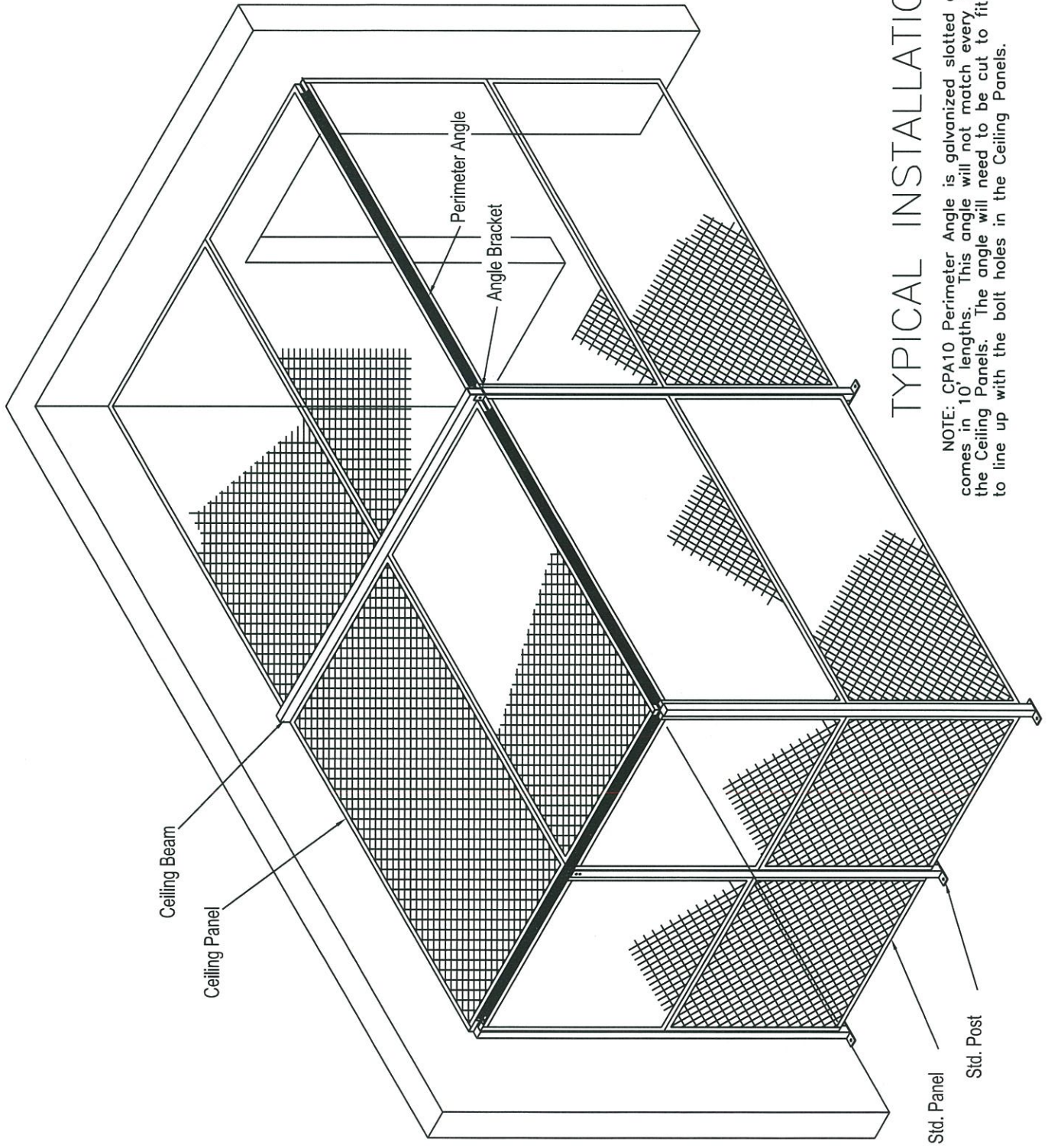

TYPICAL INSTALLATION

NOTE: CPA10 Perimeter Angle is galvanized slotted angle that comes in 10' lengths. This angle will not match every bolt hole in the Ceiling Panels. The angle will need to be cut to fit and adjusted to line up with the bolt holes in the Ceiling Panels.

Typical Ceiling Application

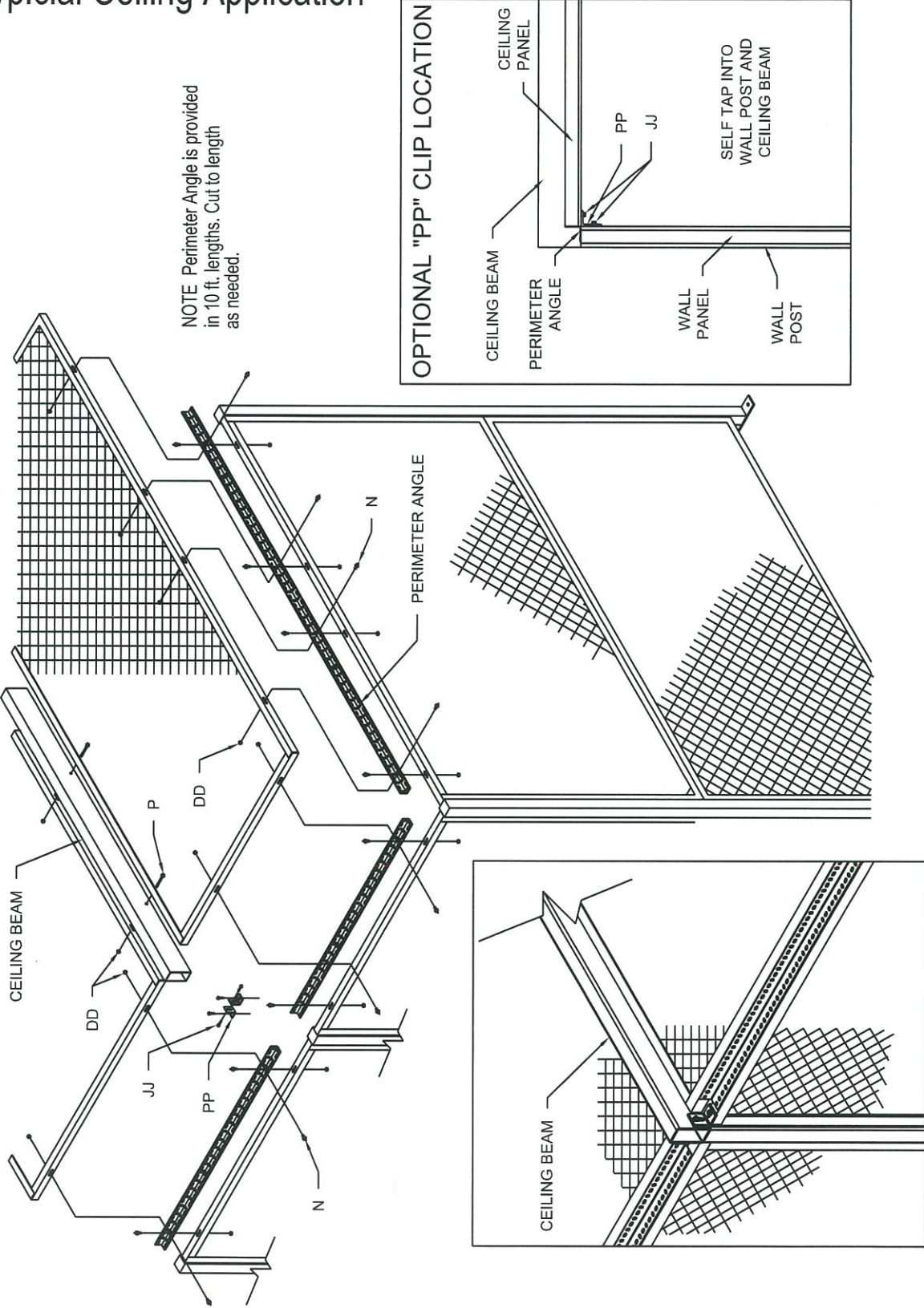

NOTE: ITEMS PP & JJ ARE SUPPLIED FOR TEMPORARY BRACING DURING CEILING INSTALLATION IF DESIRED.

JSC (Support Post)

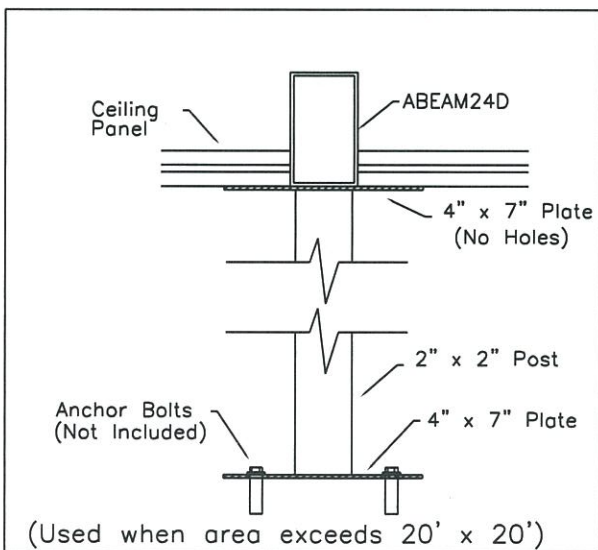
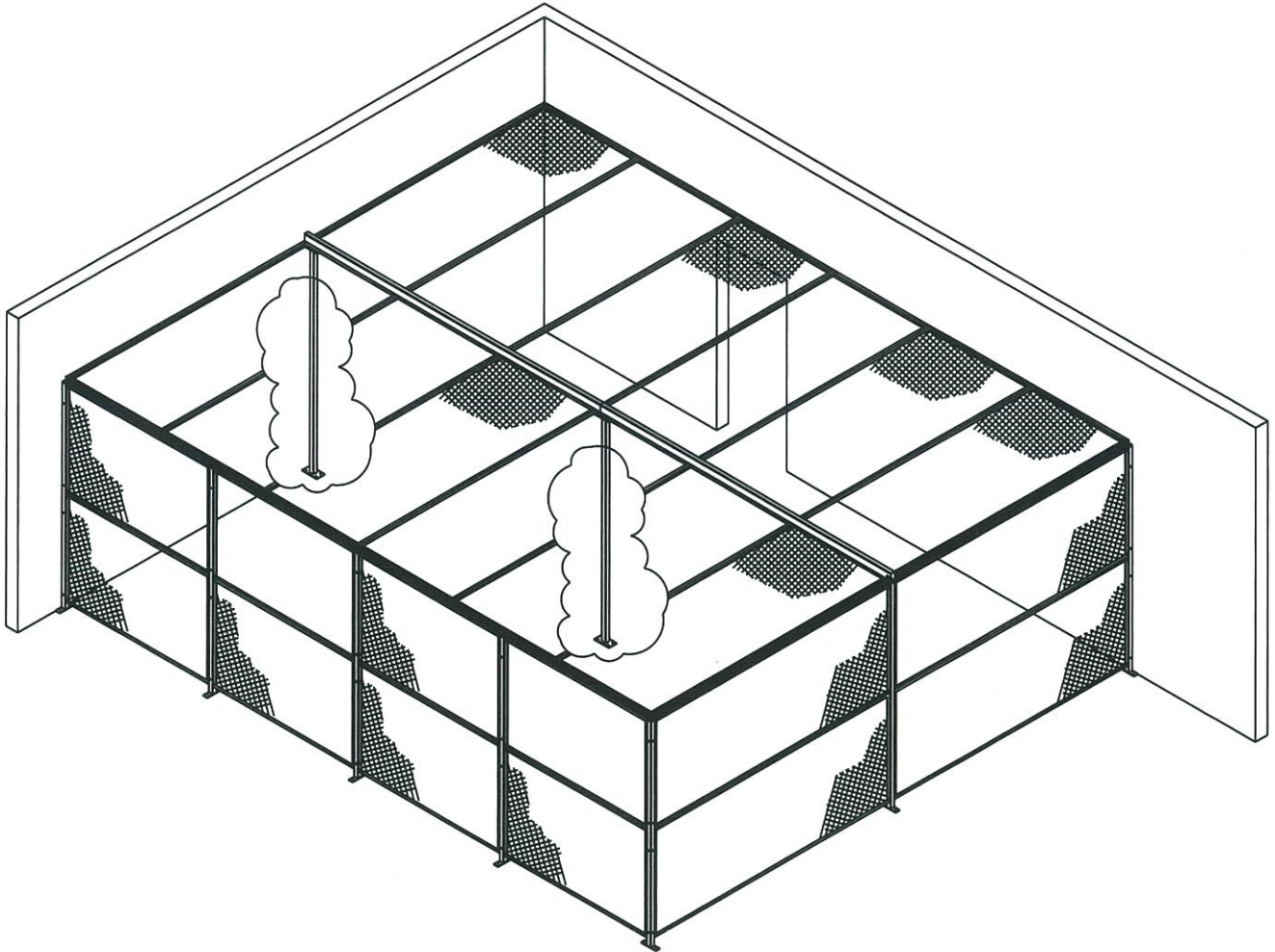

Support Post (JSC)

Option V7 Adaptor Bracket

(Use This Option When Post is Not Available.)

When V7 adaptor is in line with a panel framing member.

(Front View):

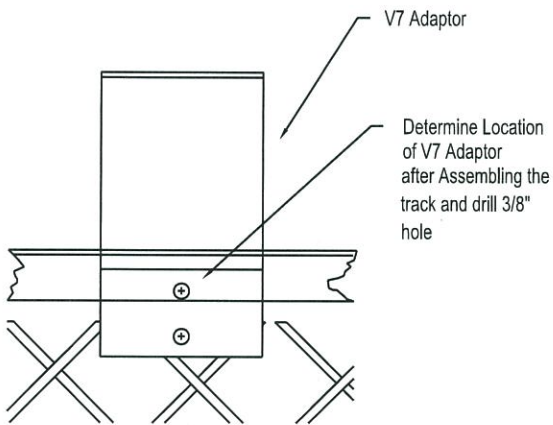

(Side View):

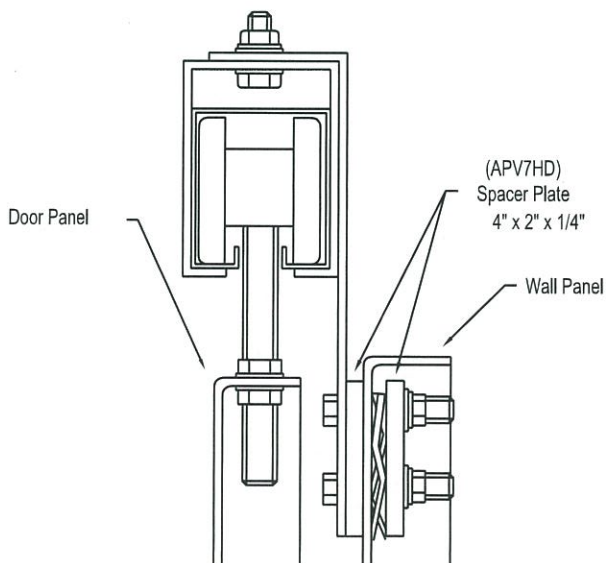

When V7 adaptor is in line with wire mesh of panel.

(Front View):

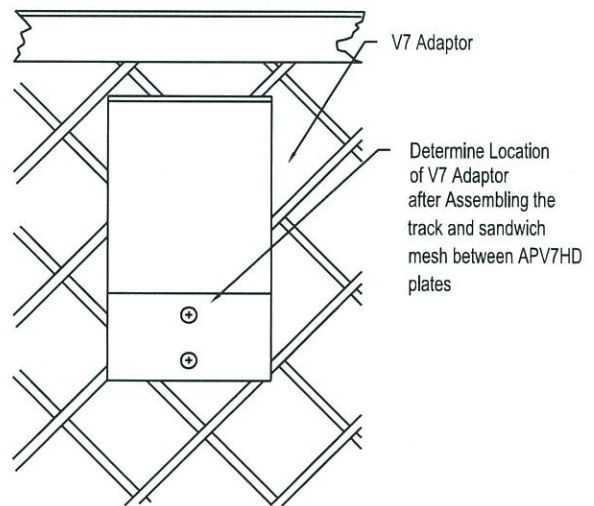

(Side View):

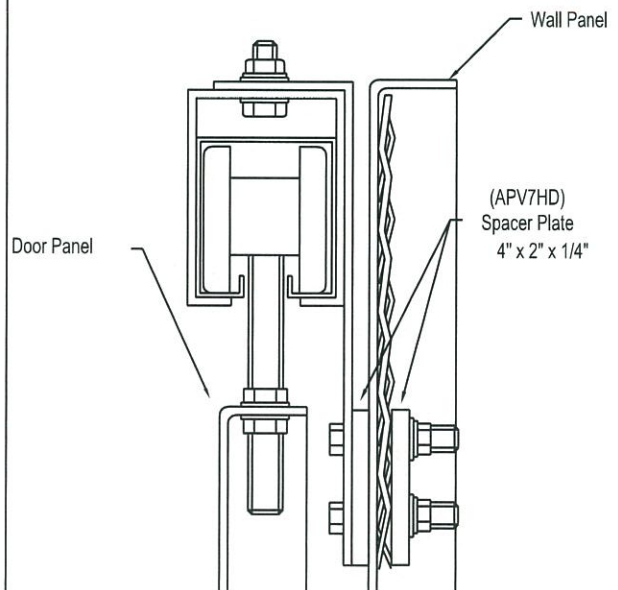

This guide covers basic installations using stock items only.

Your particular cage requirement may not be covered by the details contained herein and may require field modifications not described. If you have any questions regarding your particular installation, please locate the order number on your packing list and call the phone number below to speak with a customer service representative.